

## **C30-6-024 CERAMIC TWEETER**

The **C30-6-024** is a 1.2 inch tweeter with ultra hard [ceramic dome](#) in a 82 mm frontplate. Anti-resonant cutout fills in the ceramic dome provide for damping of the dome resonance. A neodymium overhung motor design with vented aluminium voice coil former guarantees low energy storage and excellent heat transfer. The soft fabric surround and ferrofluid with high viscosity center the moving parts with distinctive linearity. We recommend our **C30-6-024** in an application above 1800 Hz.

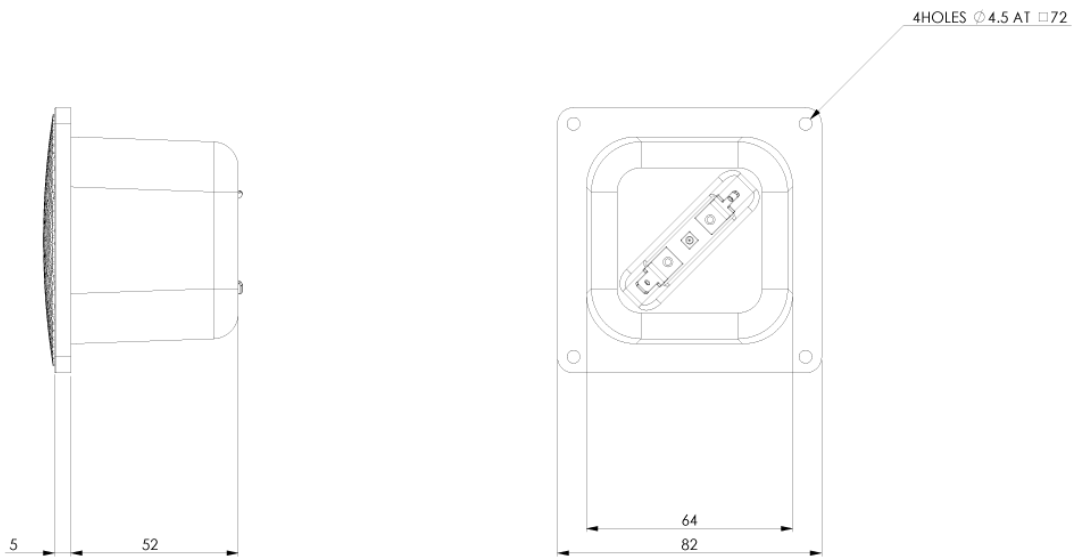

Dome material	Ceramic
Application	Tweeter
Overall diameter	82 x 82 MM
Cutout Diameter/Square	64 x 64 MM
Overall depth	57 MM
Motor assembly depth	--
Motor assembly diameter	--

## MAIN FEATURES

special dome cutouts  
 overhung motor design  
 soft fabric surround  
 vented vc & pole piece  
 ferrofluid filling  
 1800 HZ - 28000 HZ

## MECHANICAL DATA

Specification	Value	Unit
Overall diameter	82 x 82	mm
Cutout Diameter/Square	64 x 64	mm
Min. frontplate thickness	5	mm
Overall depth	57	mm
Motor assembly depth	--	mm
Motor assembly diameter	--	mm
Screwfitting	DIN 7984 / Ø 4.50	mm
Terminal	+: 4.8 x 0.8 / -: 2.8 x 0.8	mm
Shipping weight (pair))	1.1	Kg
Shipping box size (pair)	130 / 130 / 190	mm

## THIELE/SMALL PARAMETERS

Specification		Value	Unit
Sensitivity (2.83V / 1m)	Spl	93	dB
DC-resistance	Re	6.31	Ohm
Resonance frequency	Fs	942	Hz
Equivalent volume of air	Vas	-	ltr
Mechanical Q	Qms	2.04	
Electrical Q	Qes	1.19	
Total Q	Qts	0.75	
Effective piston area	Sd	8.55	Cm2
Moving mass	Mms	0.49	g
Suspension compliance	CMs	0.073	mm/n
Mechanical resistance	Rms	1.2	Kg*s

## VOICE COIL PARAMETERS

Specification		Value	Unit
Power handling	P	120	W
Linear excursion	Xmax	+/-0.5	mm
Voice coil diameter		19.4	mm
Voice coil former material		Al	
Voice coil material		Cu	
Voice coil inductance	Le	0.03	mH
Force factor	Bl	3.64	N/A
Motor type		Overhung	
Ferrofluid filling		Yes	

## FREQUENCY RESPONSE [DB]

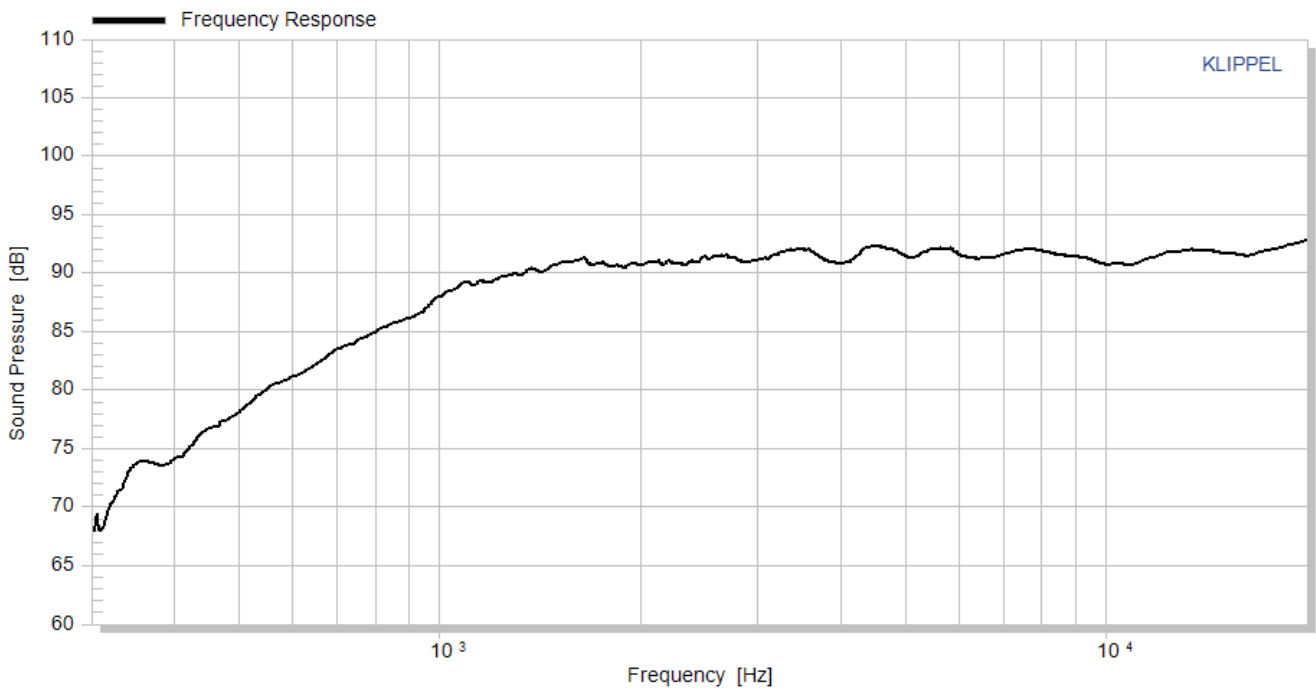

## IMPEDANCE [OHM]

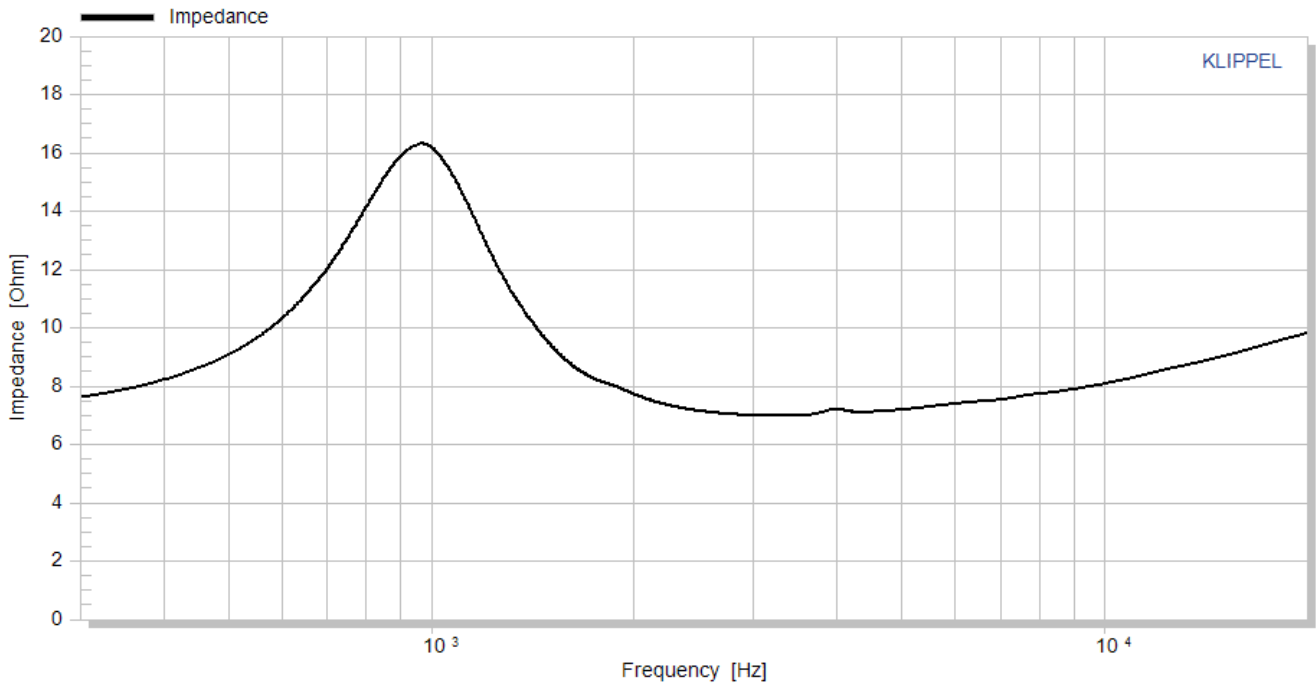

## HARMONIC DISTORTION [%]

