

Frugel-Horn Mk3

25-february-2012 | © 2010, 2012 Frugal-Horn.com

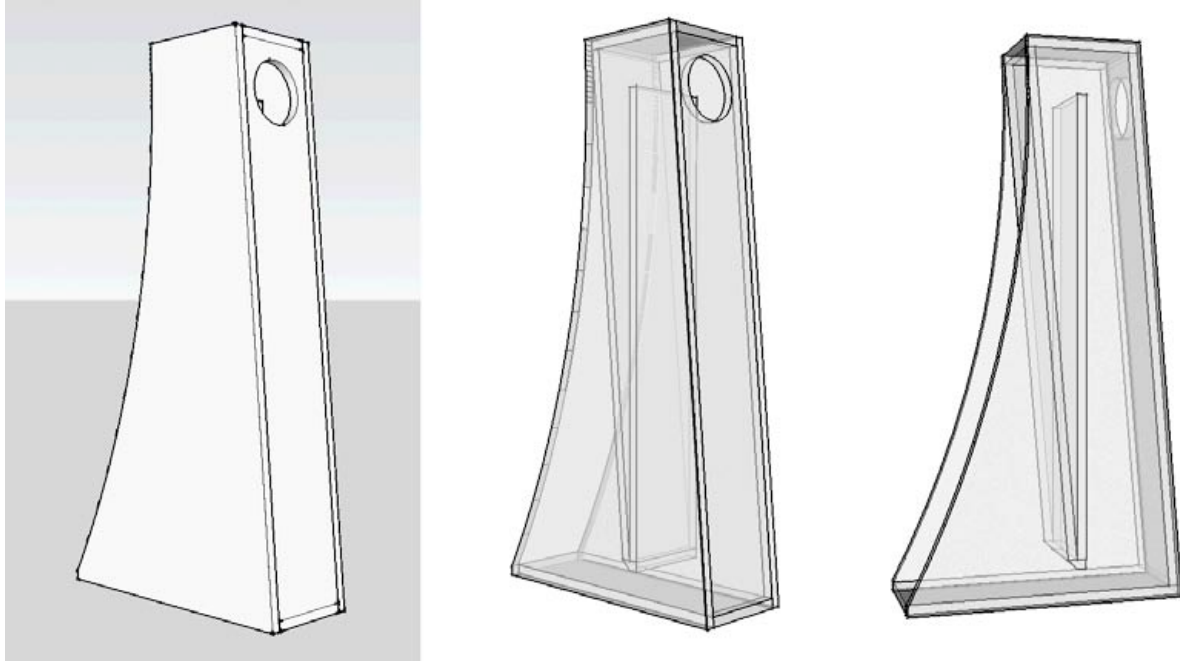

In late 2006 – '07 a small group of enthusiasts collaborated to develop a compact, inexpensive corner-horn design for the DIY community. This project became the very successful Frugel-Horn, which even spawned an extremely expensive commercial adaptation.

The Frugel-horn Mk3 [FH3] is a ground-up new design, with the objectives of improving upon the performance of the original box in a substantially simpler cabinet that would be tolerant of a wide range of drive units. Topologically, it is a tapped hypex corner-horn (approximated by 2 conical sections) with an internal choke serving as a low pass filter. The curved terminus is carried over from Ron Clarke's contribution to the original cabinet, and helps the wavefront exiting the horn mouth to return to its more natural spherical shape.

The cabinet has to date been successfully tested with Fostex FE126En, FE126e, FE127e, FE138eSR*, Mark Audio CHR-70, CHP-70, Alpair7, CSS EL70, and Tangband W5-1611. Suitable drivers should fall into, or be near the envelope of parameters defined by this set of drivers. Additional drivers will be added to the above list as and when they are tested. Adjustment & tuning of the cabinet is accomplished with varying amounts of damping, and proximity to rear boundary walls / corners.

* (this driver does bass really well in FH3, but has other issues which preclude it being recommended)

FH3 is made freely available for DIY builders to make their own cabinets; we see it as an introduction to back-loaded horns, from which people may wish in future to move on to larger and / or more complicated designs.

Use of deflectors & supraBaffles yet to be explored.

Note: any commerical entity intent on manufacturing complete speakers or flat-paks for resale will need to follow the guidelines on the Frugal-Horn site: www.frugal-horn.com/use.html

This project's contributors:

DIYers who went ahead, assisted in beta testing, offered comment and suggestions

diyAudio: host for interactive discussion threads

Scott Lindgren <<http://www.wodendesign.com/>> design & documentation

Ron Clarke: the curved mouth

Chris Bobiak: Original test builds & drawing contribution

Colin Topps: drawing contribution

Your name here: you can help with FAQ, assembly diagrams & pictures, photo gallery.

Probably more.

Local cottage industry to make & distribute flat-paks encouraged, please contact Dave (david@planet10-hifi.com)

Drawings/Contents (provisional)

io/ Intro
i1/ Pictures
i2/ Notes

FH3-0/ Plan 15mm
FH3-0.1/ Details 15mm
FH3-1/ Plan 15mm + 18mm baffle
FH3-2/ Plan 18mm
FHx/ Plan 5/8"
FHx/ Plan 3/4"

FH3-5/ Alternate Choke Point Execution
FH3-6/ Side pattern creation
FH3-7/ Side template (metric 15mm)
FH3-8/ Side template (imperial 15mm)
FH3-9/ swappable supraBaffle (updated)

D-0/ Damping
D-1/ full size side felt template (15mm)

C-0/ 5x5 15mm cut plan
C-1/ 4x8 15mm cut plan
C-2/ 4x8 18mm simple cut plan
C-3/ 4x8 18mm cut plan (updated)
C-4/ 4x8 18mm alternate cut plan (updated)

please email me <david@planet10-hifi.com> with corrections & suggestions to make this document more useful

Major Sponsors
& Cheerleaders



Pictures

25-february-2012

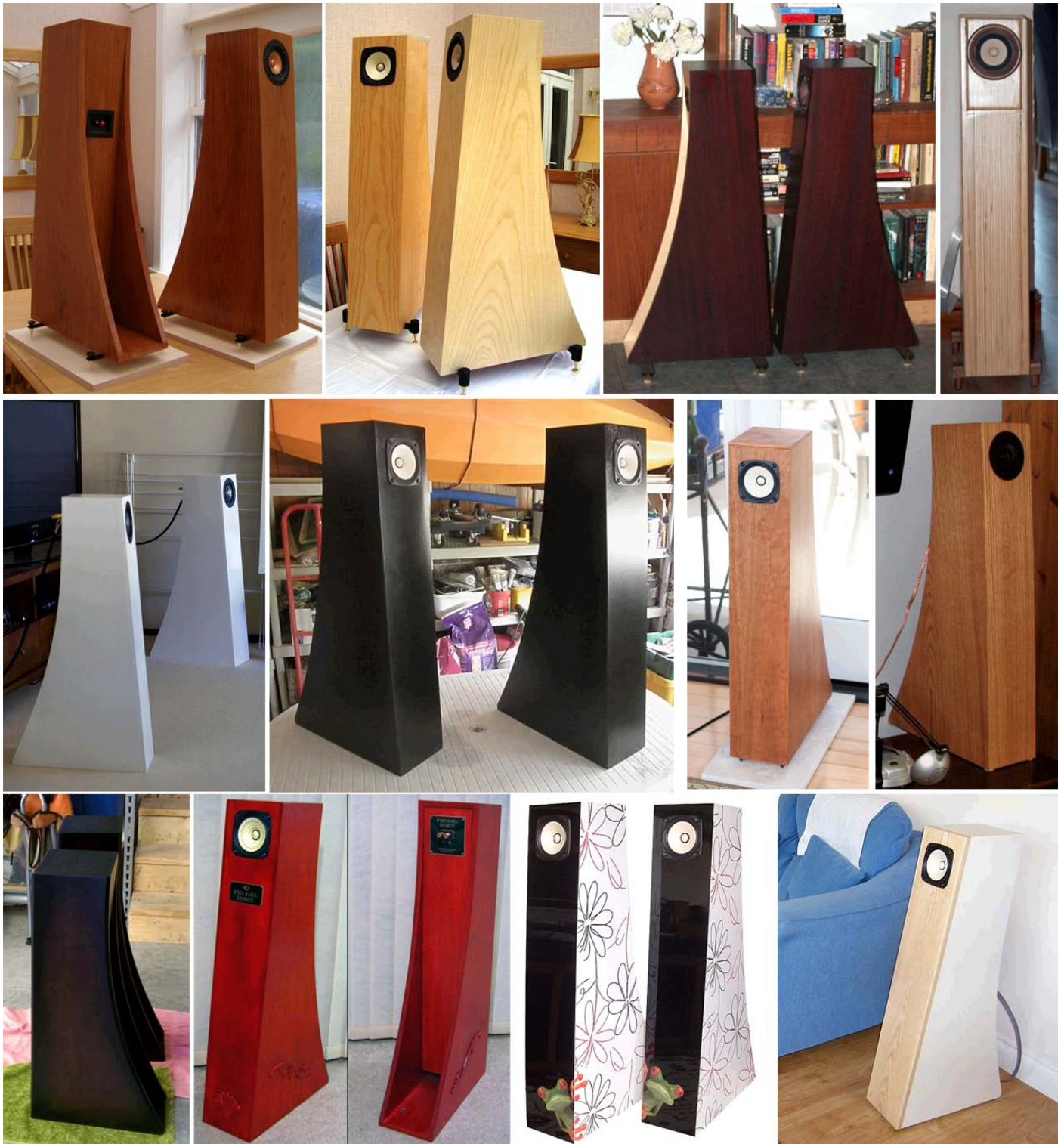

more pictures at <http://www.diyaudio.com/forums/full-range/199849-fh3-build-gallery.html>

Notes

30-september-2011

Notes

o/ quality multi-ply/plywood is recommended. In general, void free, the greater number of plies the better

- 1/ reference build is 15mm plywood, to allow rebate for some drivers 18mm baffles recommended (ie Alpair 7)
- 2/ if MDF or particle board used a minimum panelthickness of 18mm, good multi-ply minimum 12mm
- 3/ the most difficult detail in the build is the joint at the bottom of back, inside divider. A number of means to achieve this are detailed
- 4/ a removable vestigial supraBaffle is shown that allows experimentation with different drivers
- 5/ a full size supraBaffle can be added as shown in the Frugel-Horn Mk1 document
- 6/ A full height rear deflector based on that shown in the Frugel-Horn Mk1 document can be added
- 7/ a stealthWoofers based on a full-height deflector is under development.

Donations

Frugel-Horns have always been free for DIY builders to construct. We received many inquiries by builders who wanted to send some money. For this iteration we would encourage you to pay it forward with a donation of money or time to some charitable organization. Listed below are some chosen by the three main contributors to the design & documentation. Quite literally, every little helps.

Royal British Legion: www.britishlegion.org.uk
Alzheimer's Research UK: www.alzheimersresearchuk.org
Cancer Research UK: www.cancerresearchuk.org
Donor's Choose: www.donorschoose.org
Save The Children: www.savethechildren.org
Big Brothers Big Sisters: www.bbbs.org
[Chris 1](#)
[Chris 2](#)
[Chris 3](#)

for those without major woodworking kit, a growing number of independent flat-pak vendors are coming on-line. Canada (North America), Netherlands & UK (Europe) & Australia as of this document revision

Comments & tips pulled from forum posts

Bob Brines:
Taking Colin's diagram (*sheet C-2*), here is how I would one-man it out of a 4x8 panel.

o. Build yourself a T-square cutting guide out of scrap material. You can find the instructions out there on the Internet.

oo. I have a 3'x6' sacrificial table top on a pair of saw horses. I can still manage to get a 4x8 sheet of plywood on it, but I can no longer get a sheet of MDF on it. For MDF, I just drop the sheet on the driveway and put 4 2x4's under it.

1. With a circular saw, cut off the 4 140mm pieces.

2. Cut between the remaining doubled pieces.

3. Now you can rip the individual pieces on a table saw as long as you can rig some kind of outflow table. I have a jig that fits my router table so that it can double as an outflow table for the table saw. Of course, if you don't have a table saw, you can do this with a circular saw and the rip fence you made above.

You can get the two cross cuts done at Lowes'/HD (speaking to the USA now), but my experience is that their panel saws are not square in any axis and I have to re-cut the ends. Also, the utility blade in their saw really tears up the cut. I have a 60 tooth blade in my circular saw that does an acceptable job. Not as good as the 80 tooth blade in my table saw, but acceptable.

That's my technique. YMMV.

Bob

PDRCanada:
Another tip for cutting sheet goods on saw horses.....

Go to your nearest hardware store buy a 2'x4' pc of 2 or 3" white styrofoam and a roll of duct tape.

Cut the styro to match the top of your saw horses.....use the duct tape to fasten it around the top of the horse.

You can now cut your sheets with out hanging them over the saw horses. Just cut thru the styro.....make sure your styro is deeper than your saw cut.

When the styro gets beat up...remove and replace.

This method is used on jobsites all over to cut large panels.

Poultrygeist:
After much frustration in searching for 1/2" (12mm) cotton or wool felt I found an unlimited supply at my local auto junk yard. The carpet backing from 1990's Fords is 1/2 inch thick, works great and costs nothing. Had it not been up for sale I would have scavenged my own Mustang but instead I found a F150 donor which surrendered enough felt for a herd of horns.

Notes:

- 1/ drawn with 15mm material
- 2/ optional ~300 mm wide/diameter supra-baffle not shown. Its purpose is to move the baffle-step drop off to where the horn action starts flattening lower midrange FR
- 3/ intended for Fostex FE126En, CHR-70, Alpair 7, EL70
- 4/ damping will differ for each driver

Frugal-Horn Mk3 1v0
sheet FH3-o – 15mm Plan

designed by S Lindgren | drawn by did
27-september-2011
© 2010, 2011 Frugal-Horn.com

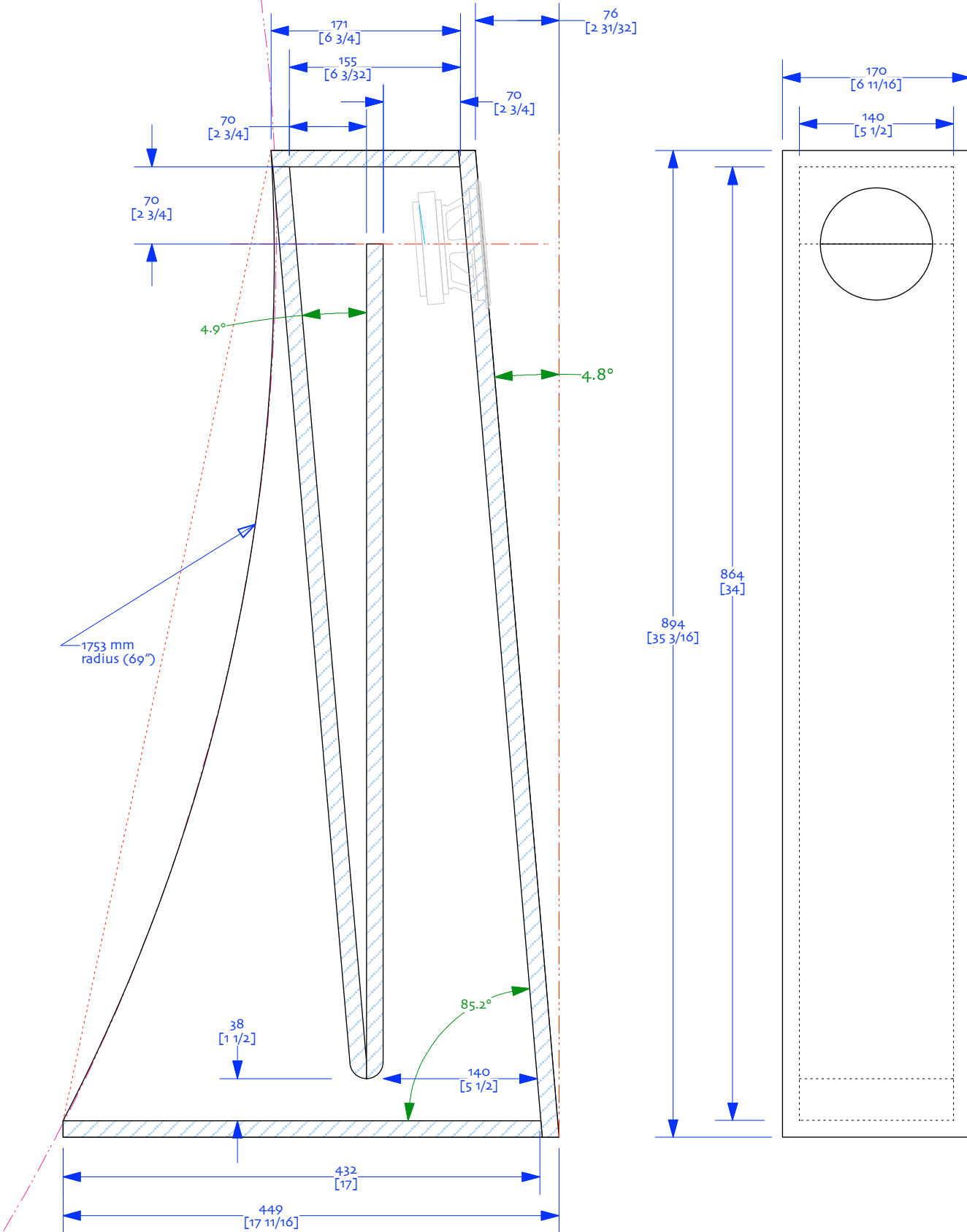

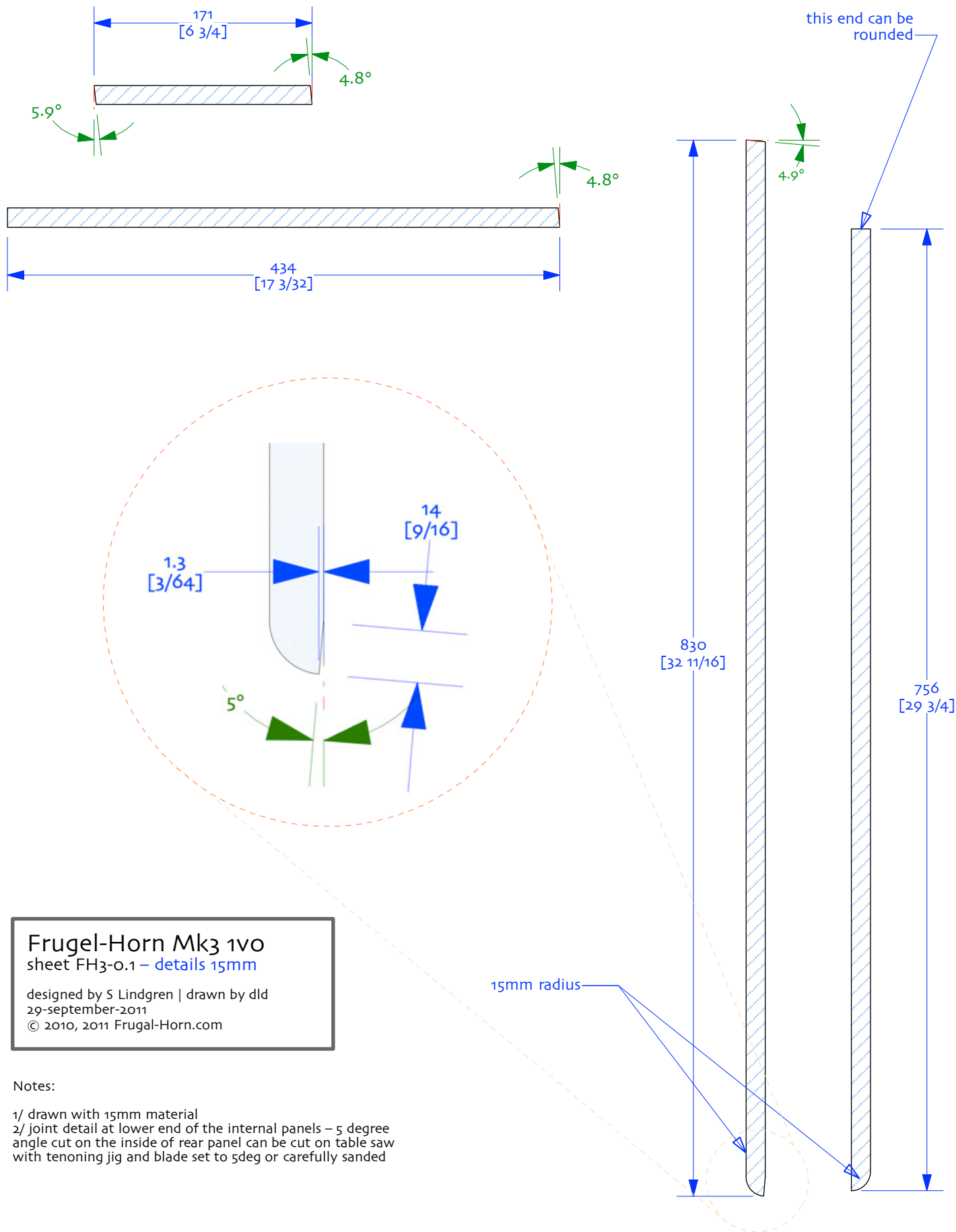

this end can be rounded

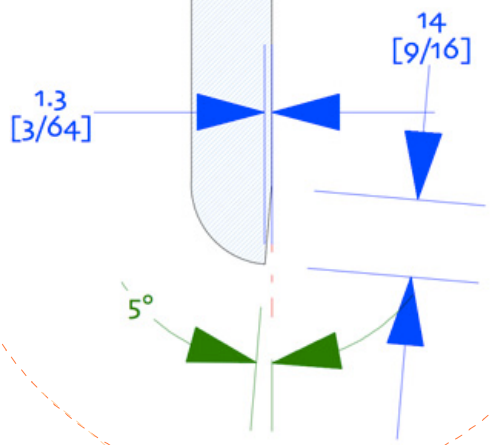

Frugal-Horn Mk3 1v0
 sheet FH3-o.1 – details 15mm
 designed by S Lindgren | drawn by dld
 29-september-2011
 © 2010, 2011 Frugal-Horn.com

Notes:

- 1/ drawn with 15mm material
- 2/ joint detail at lower end of the internal panels – 5 degree angle cut on the inside of rear panel can be cut on table saw with tenoning jig and blade set to 5deg or carefully sanded

15mm radius

Notes:

- 1/ drawn with 15mm material
- 2/ optional ~300 mm wide/diameter supra-baffle not shown. Its purpose is to move the baffle-step drop off to where the horn action starts flattening lower midrange FR
- 3/ intended for Fostex FE126En, CHR-70, Alpair 7, EL70
- 4/ damping will differ for each driver

Frugal-Horn Mk3 1vo
 sheet FH3-1 – 15mm Plan w 18mm baffle

designed by S Lindgren | drawn by dld
 27-september-2011
 © 2010, 2011 Frugal-Horn.com

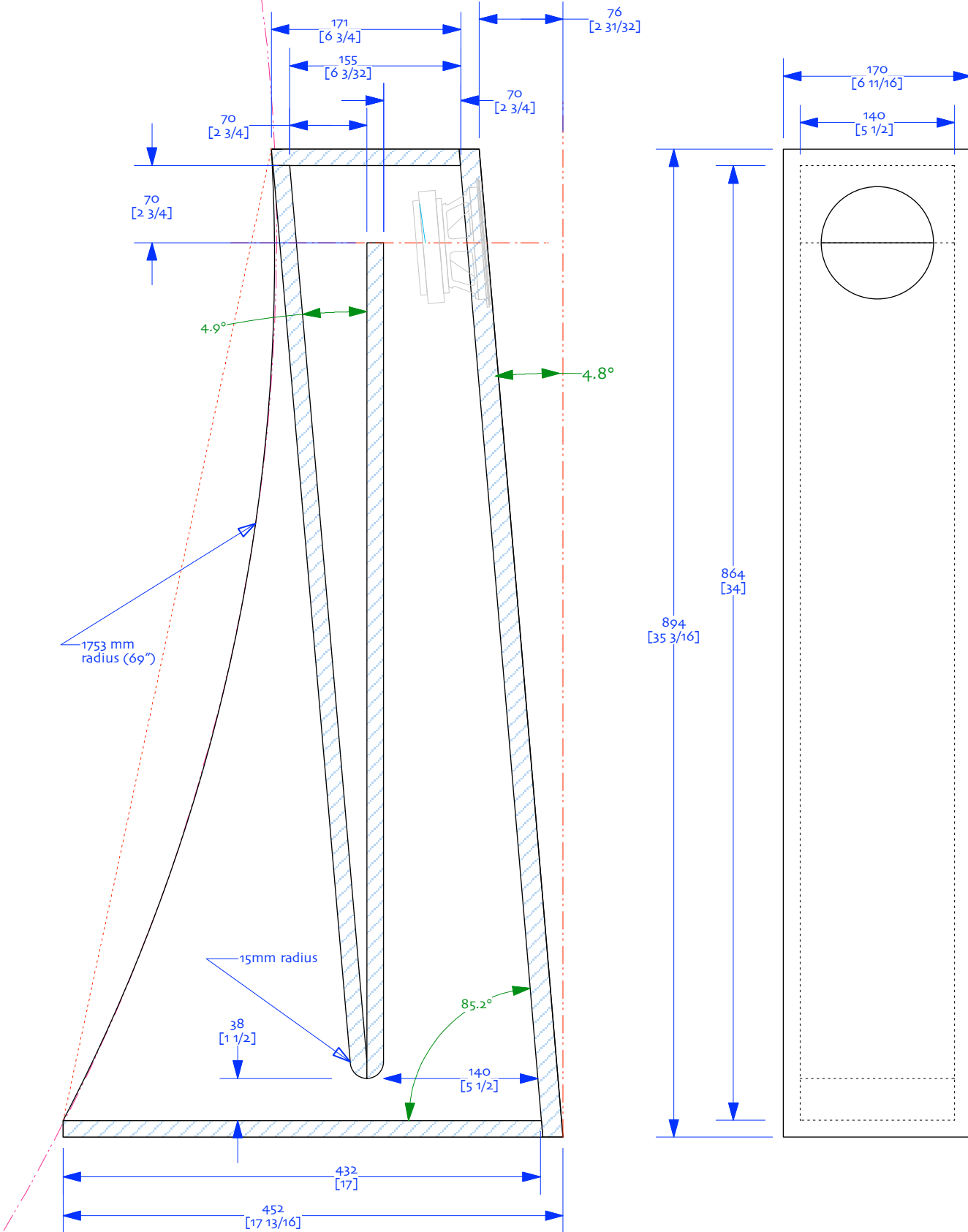

Notes:

- 1/ drawn with 15mm material
- 2/ optional ~300 mm wide/diameter supra-baffle not shown. Its purpose is to move the baffle-step drop off to where the horn action starts flattening lower midrange FR
- 3/ intended for Fostex FE126En, CHR-70, Alpair 7, EL70
- 4/ damping will differ for each driver

Frugal-Horn Mk3 1v0
sheet FH3-2 - 18mm Plan

designed by S Lindgren | drawn by did
27-september-2011
© 2010, 2011 Frugal-Horn.com

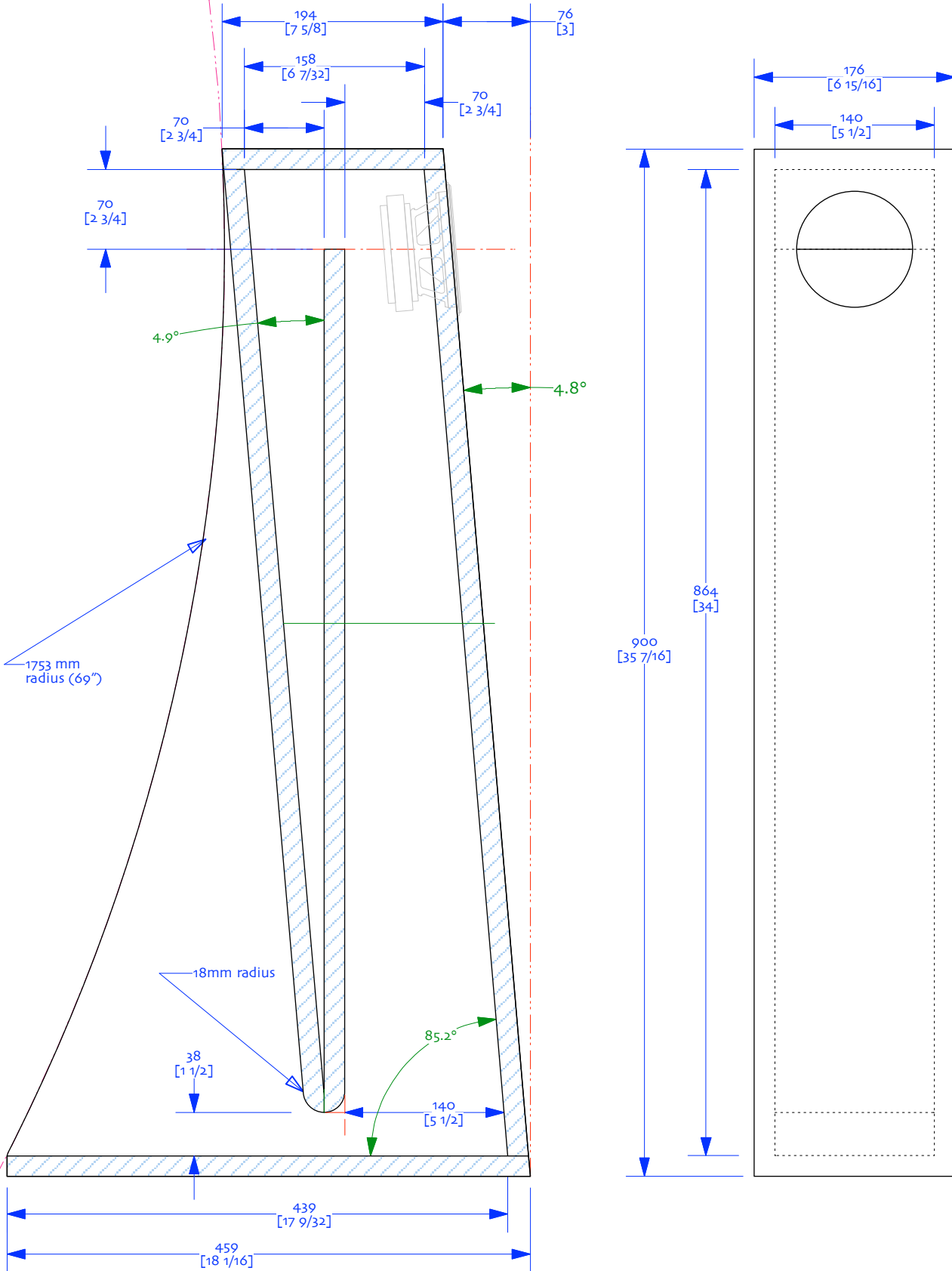

Note: example uses 15mm material

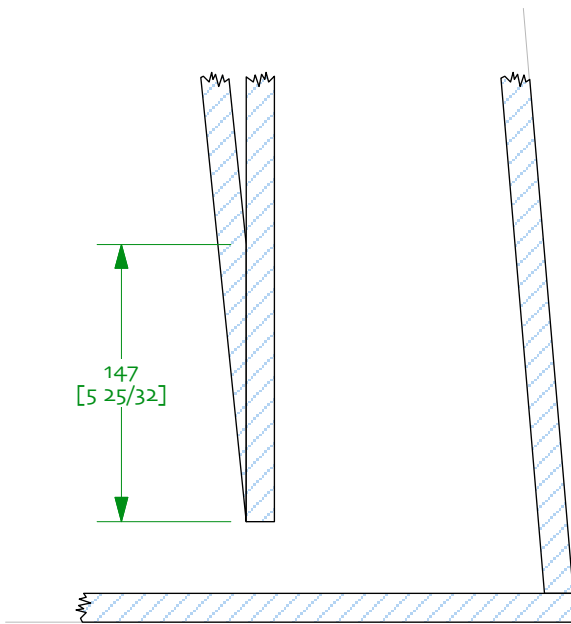

As originally designed

A difficult piece to cut

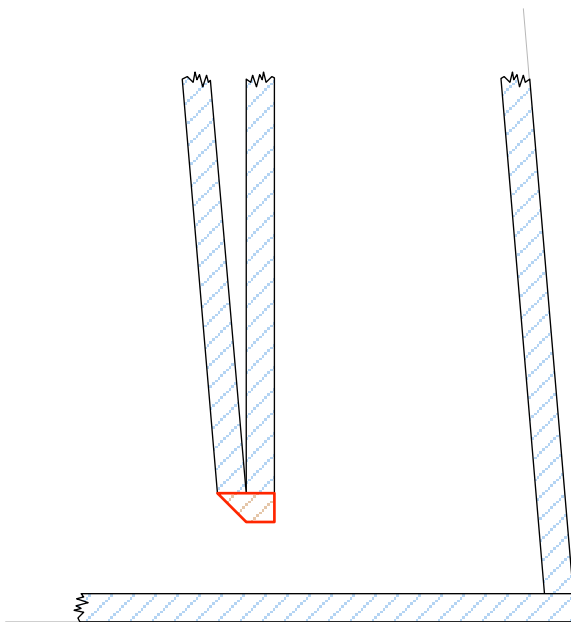

Modified for easier build

Adds an additional piece, not all that tolerant of thicker material

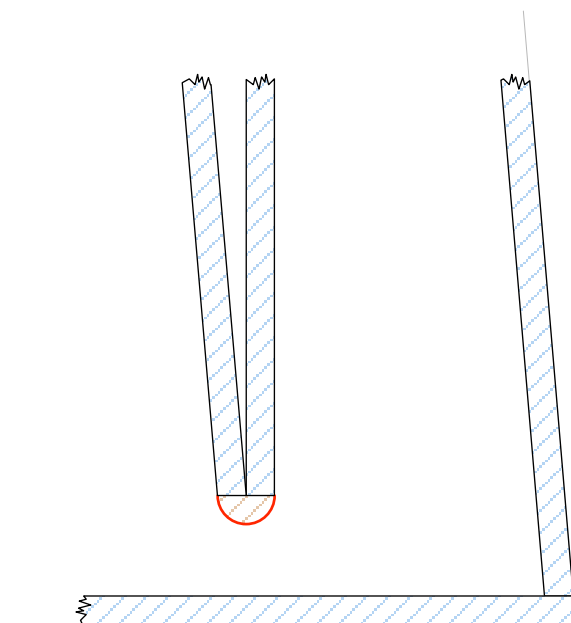

Alternate easier build

Overcomes material thickness issues.
Requires extra material – 1/2 round with radius of build material

Frugel-Horn Mk3 1v0
sheet FH3-5 – alternate choke point
execution

designed by S Lindgren | drawn by dld
27-september-2011
© 2010, 2011 Frugal-Horn.com

Frugal-Horn Mk3 1v0

sheet FH3-6 – curve chord & height

designed by S Lindgren | drawn by dld
27-september-2011
© 2010, 2011 Frugal-Horn.com

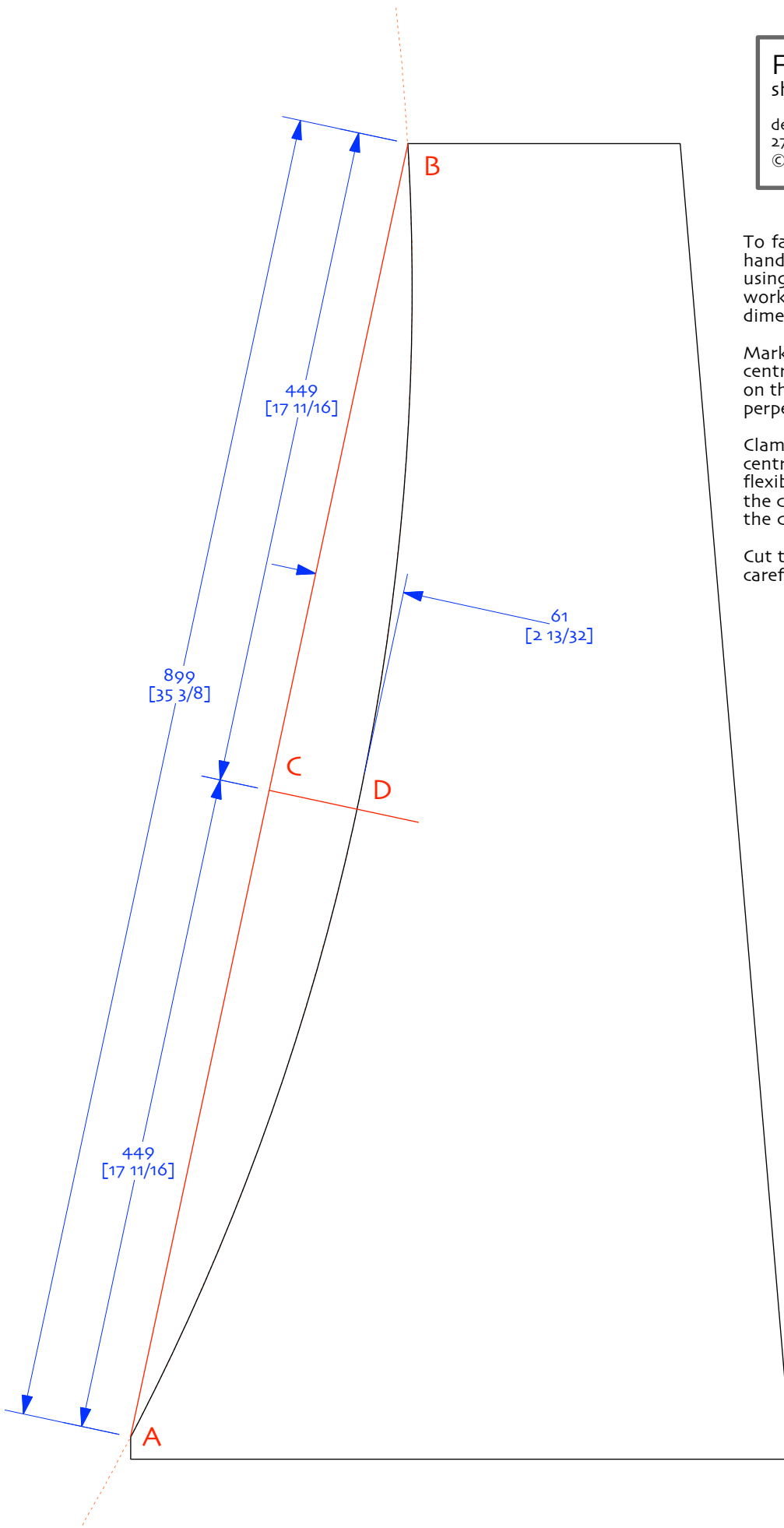

To fabricating a side panel template by hand, the curve can easily be drawn using a narrow flexible board (1/4" MDF works great) and the 4 points as dimensioned.

Mark points A,B (chord ends), C (chord centre line) and D (segment height) on the work-piece. Use a square to draw a perpendicular line (C-D)

Clamp or screw a wood block straddling the centreline at D, clamp the flexible board to this block and each end of the chord (A & B) then draw the curve.

Cut to the outside with jig or band saw, and carefully sand to line

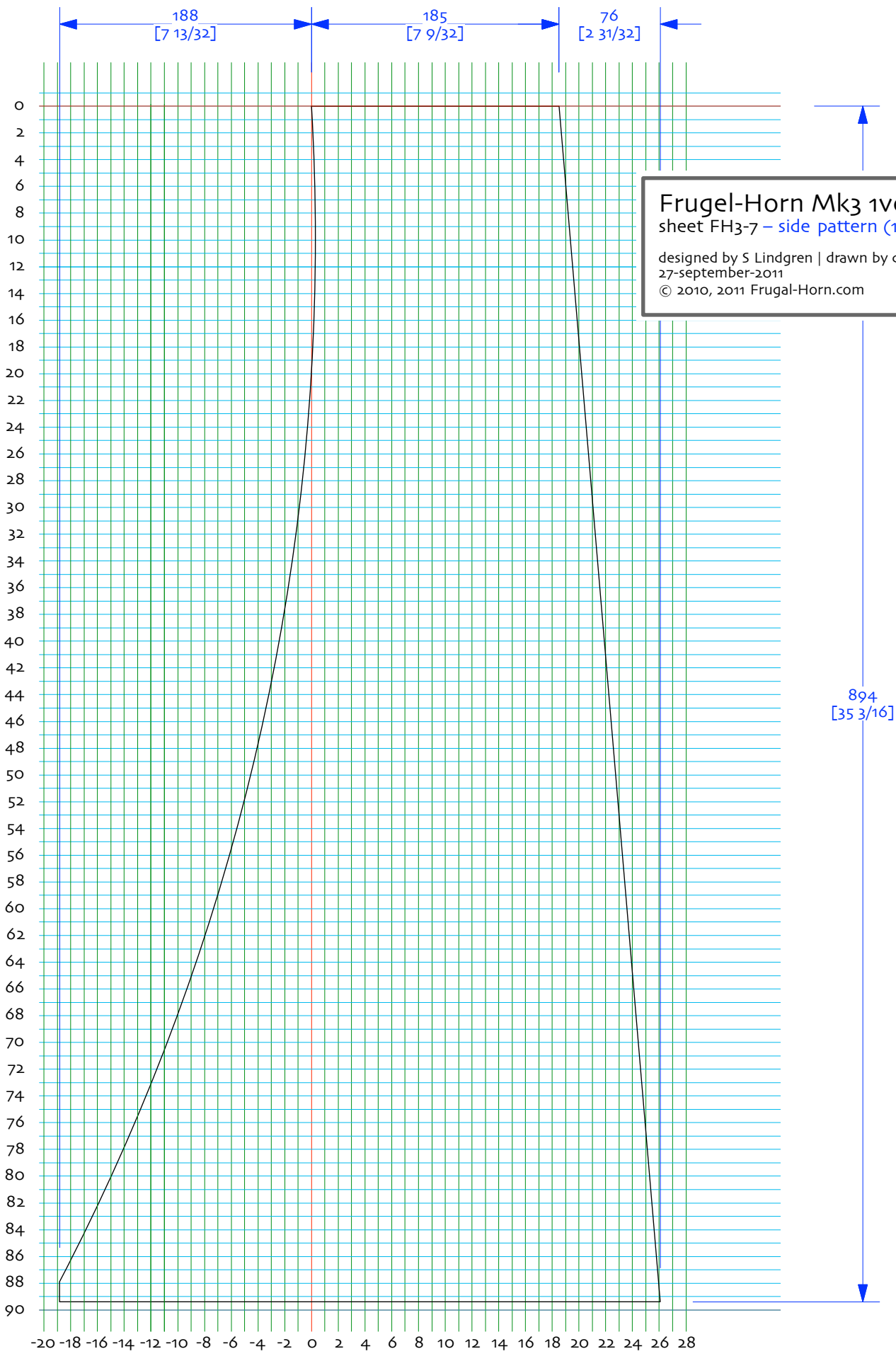

Frugel-Horn Mk3 1vo
 sheet FH3-7 – side pattern (1cm grid)
 designed by S Lindgren | drawn by dld
 27-september-2011
 © 2010, 2011 Frugal-Horn.com

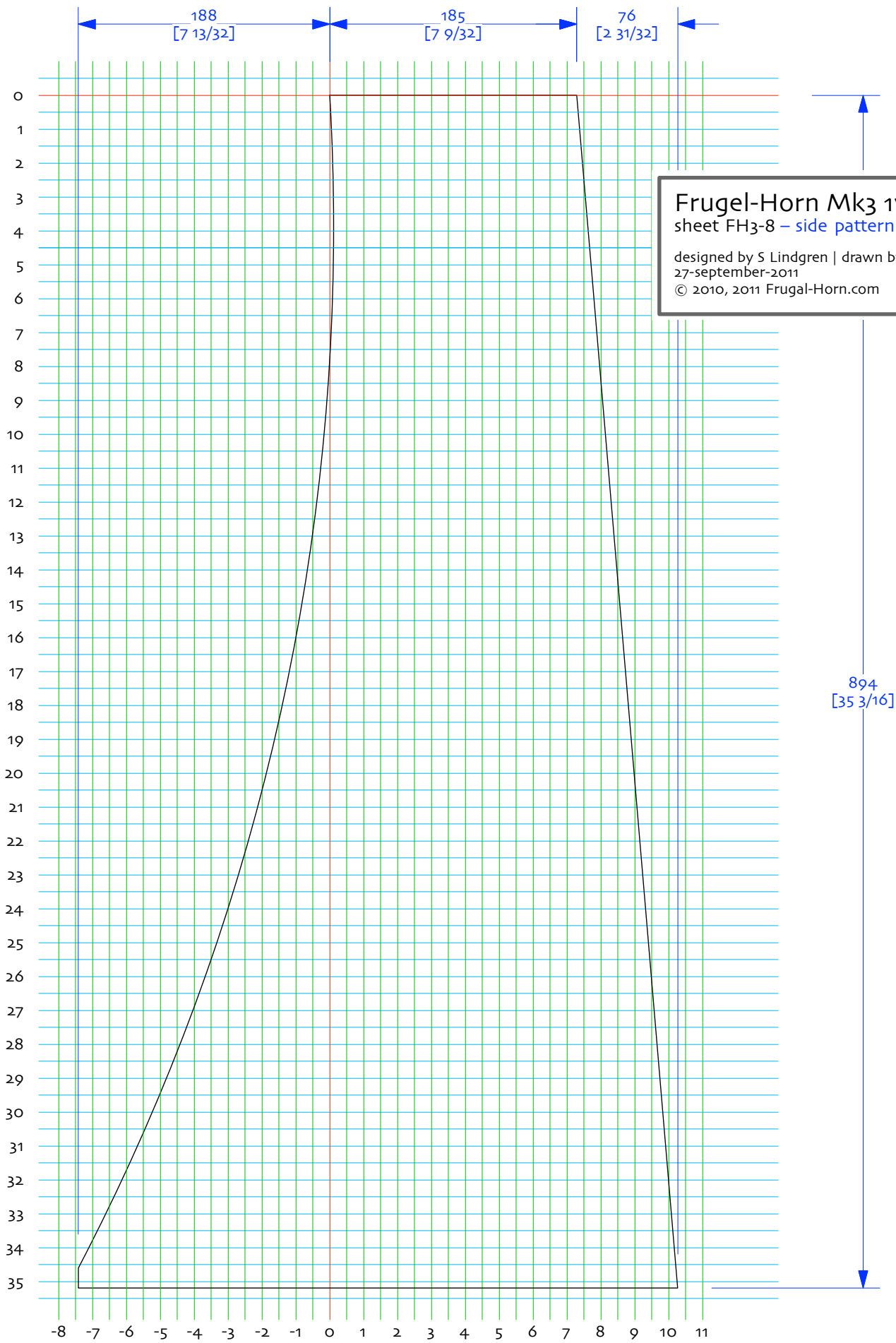

Frugel-Horn Mk3 1vo
sheet FH3-8 – side pattern (1/2" grid)
designed by S Lindgren | drawn by dld
27-september-2011
© 2010, 2011 Frugal-Horn.com

Frugal-Horn Mk3 1vo
 sheet FH3-9 – removable supraBaffle
 (15mm)
 designed by C Bobiak | drawn by dld
 26-november-2011
 © 2010, 2011 Frugal-Horn.com

Notes:

- o/ drawn with 18mm panels
- 1/ shown on FH3 in 15mm material
- 2/

these dimensions allow for a small gap to accommodate veneer, laminate etc, if needed the wings can be made tight to the sides and the vertical edges can be sanded flush.

BaffleCutout

cut out on backside of sB is 20mm down from the top (15mm panels, would be 23mm down with 18mm panels)

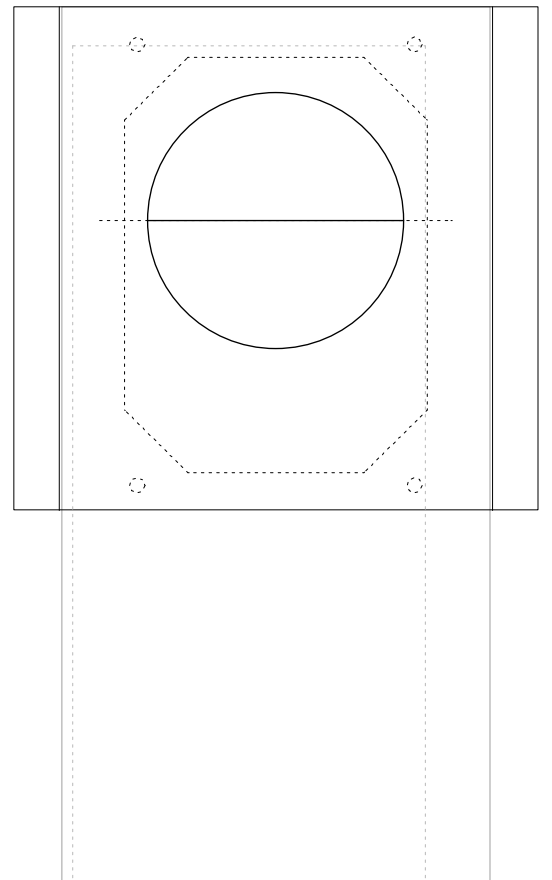
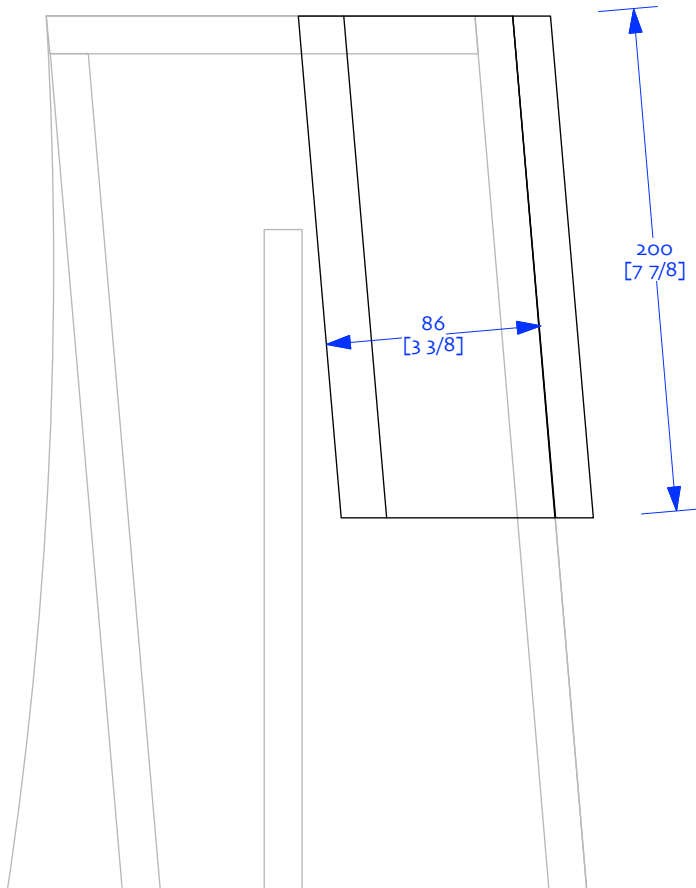
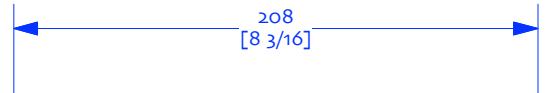
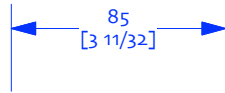
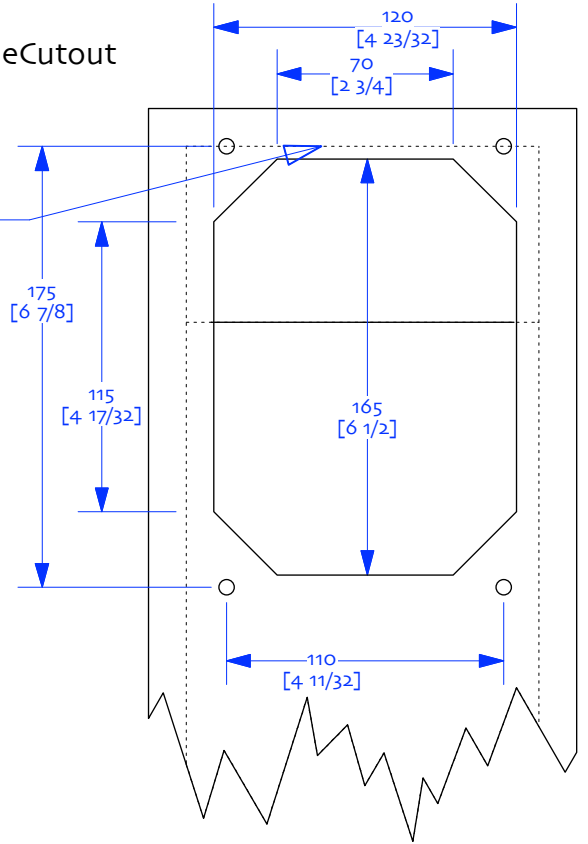
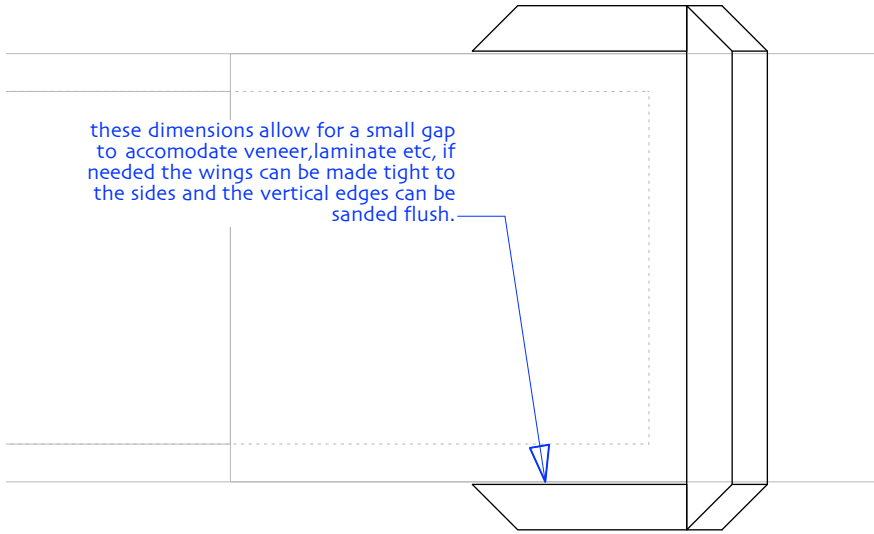

1/2" (12mm) cotton or wool felt



poly-fluff (BAF, acoustistuff, pillow stuffing -- different colours represent different "zones" to add stuffing too)

- 1/ FE126En blue + orange
- 2/ CHR70 blue + orange + 20-40g
- 3/ EL70 blue + orange + 20-40g
- 4/ A7 blue + orange + 20-40g

Frugel-Horn Mk3 1vo sheet D-o – damping plan

designed by S Lindgren | drawn by dld
27-september-2011
© 2010, 2011 Frugal-Horn.com

increasing density as you approach the point. Take the equal density fluff on the right and squeeze it into the point (~30g = 1 oz)

walls lined around driver to minimize reflections

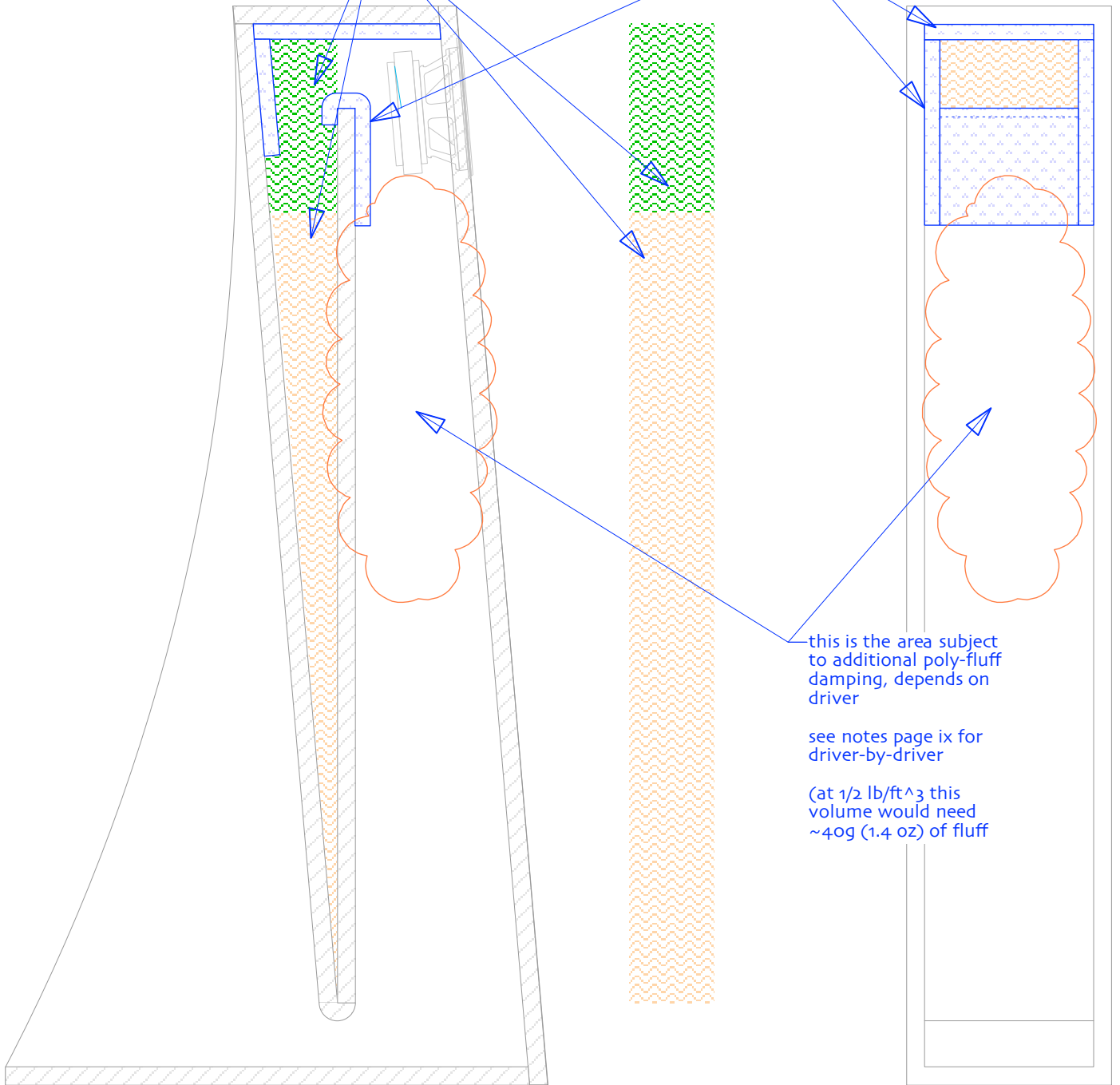

this is the area subject to additional poly-fluff damping, depends on driver

see notes page ix for driver-by-driver

(at 1/2 lb/ft³ this volume would need ~40g (1.4 oz) of fluff

Frugel-Horn Mk3 1v0
sheet D-1 – Side felt template (15mm)

designed by S Lindgren | drawn by did
27-september-2011
© 2010, 2011 Frugal-Horn.com

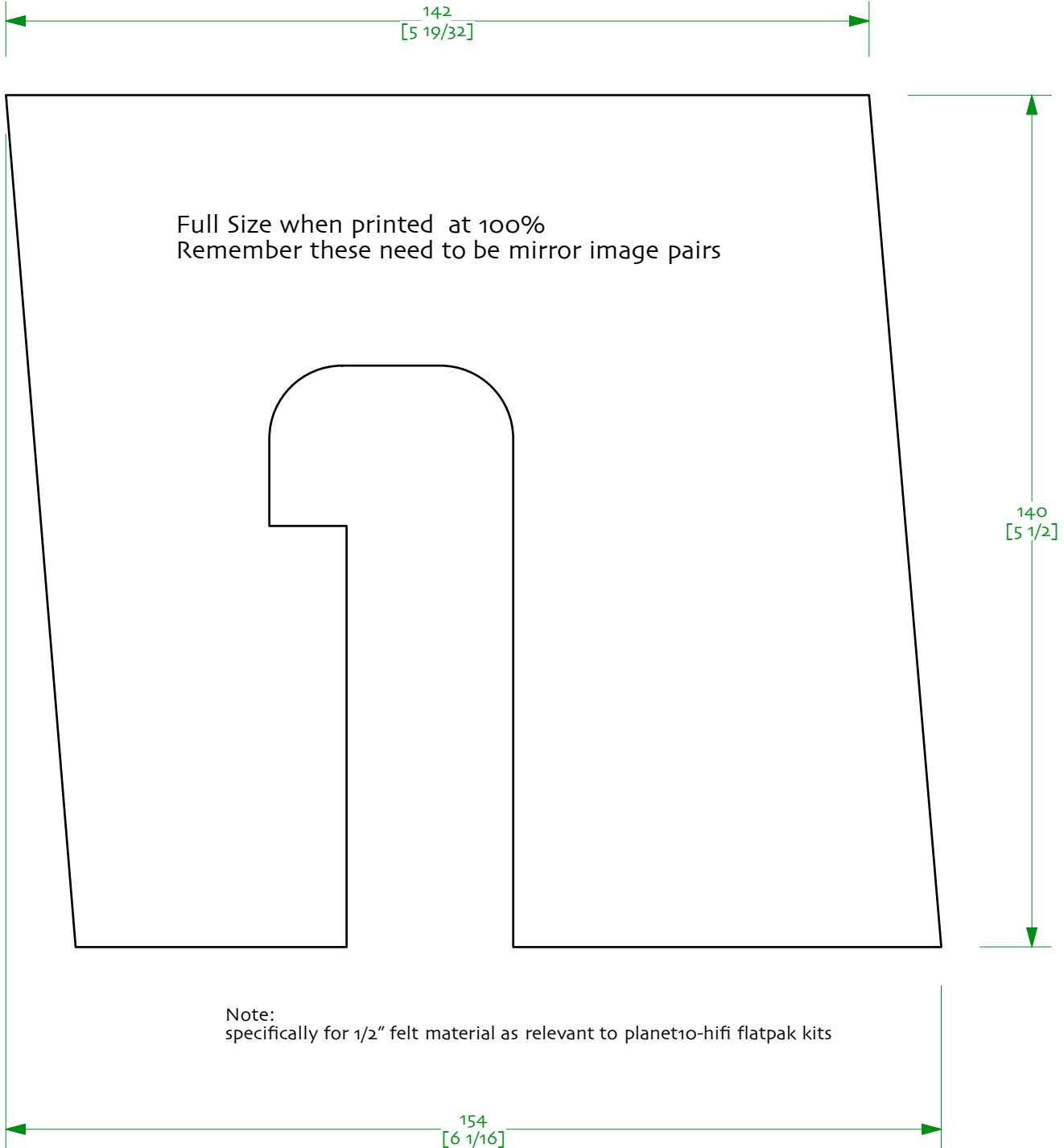

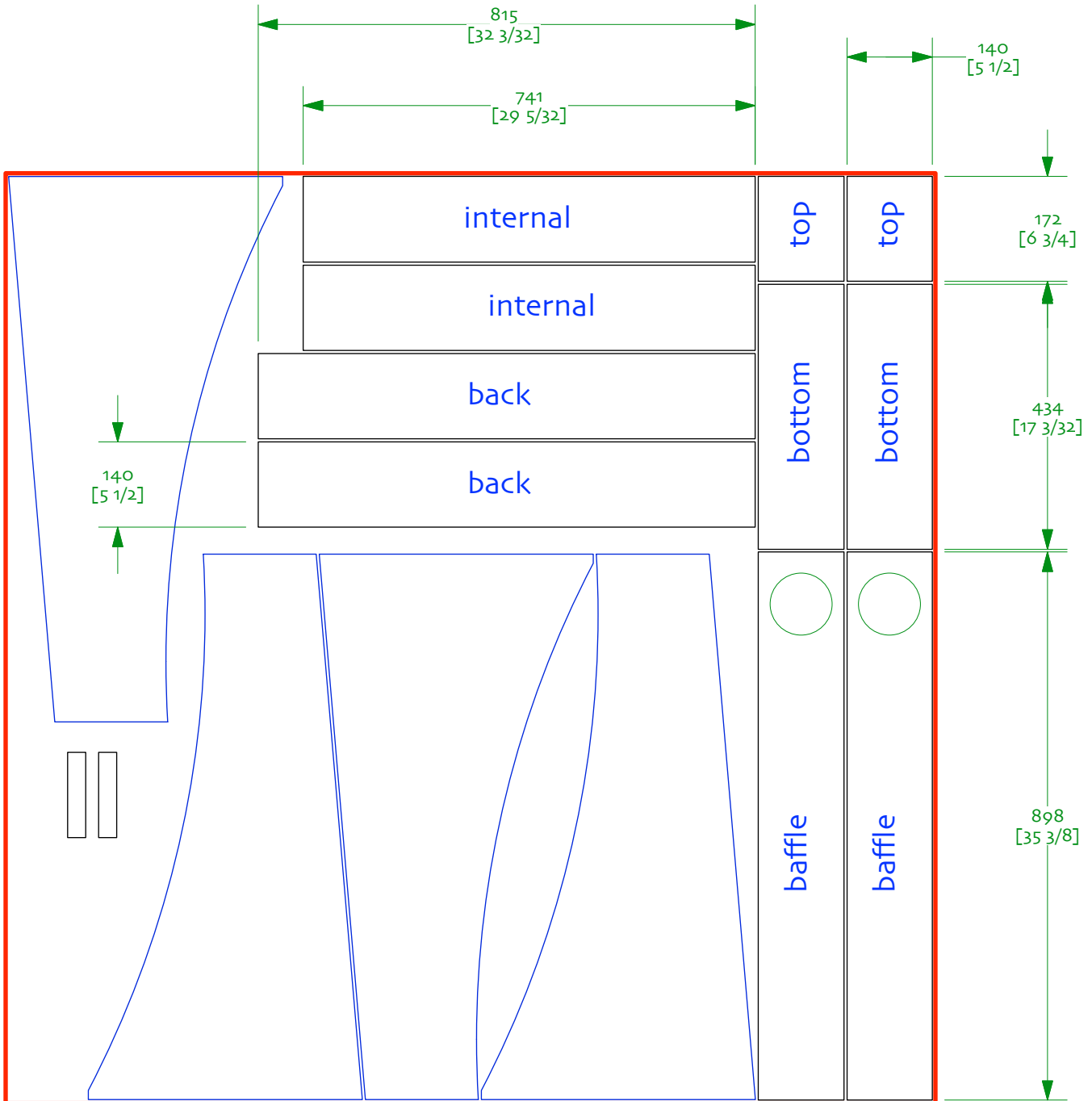

Frugel-Horn Mk3 1v0
 Sheet C-0 – 5x5 15mm cut sheet
 layout by Chris Bobiak
 drawn by dld / 27-sept-2011
 © 2010, 2011 Frugel-Horn.com

Notes:
 1/ 5mm kerf & trim allowance
 2/ very tight cut plan

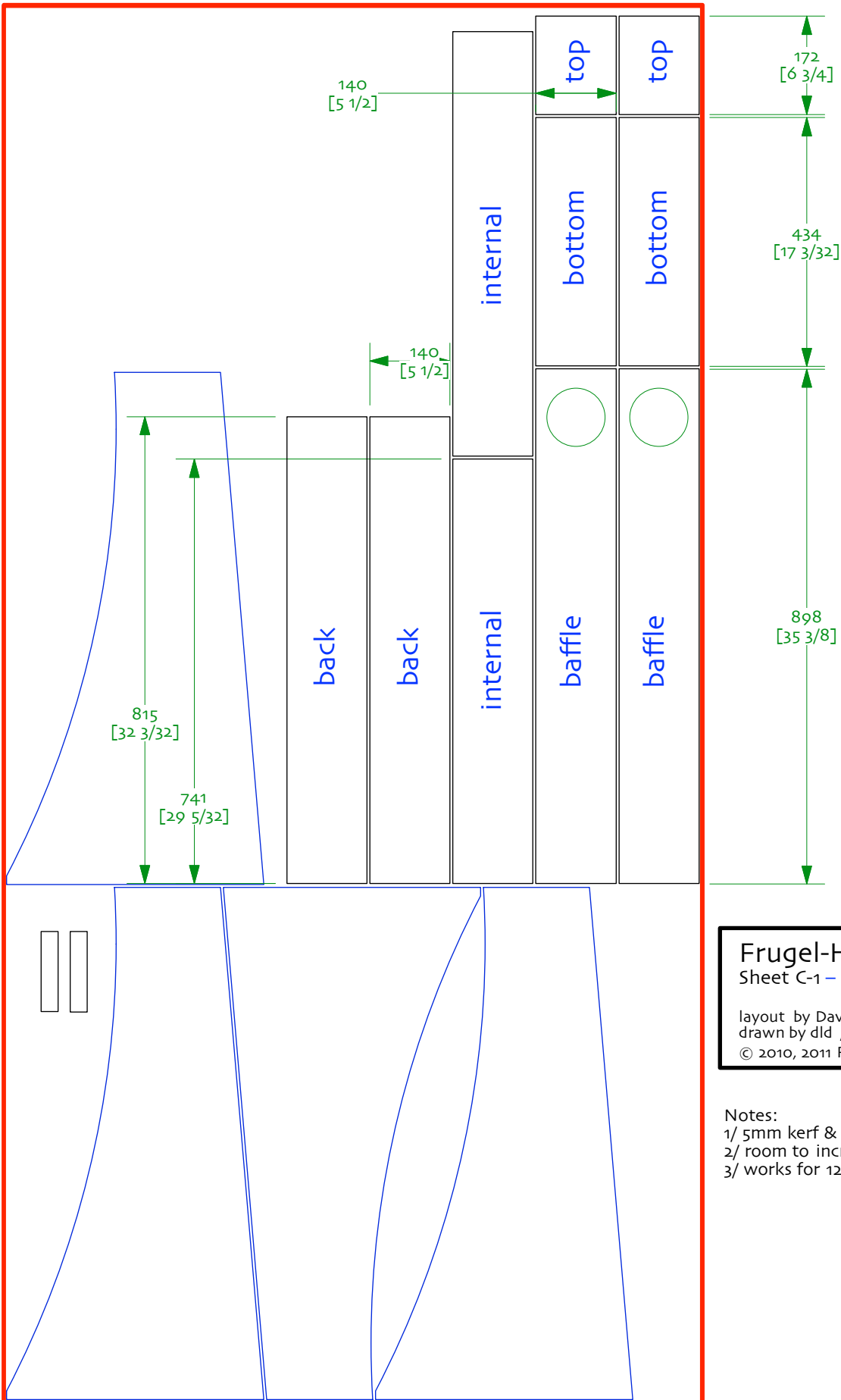

Frugal-Horn Mk3 1v0
 Sheet C-1 – 4x8' 15mm cut sheet
 layout by David Dlugos
 drawn by dld / 27-sept-2011
 © 2010, 2011 Frugal-Horn.com

Notes:
 1/ 5mm kerf & trim allowance
 2/ room to increase kerf for CNC
 3/ works for 1220x2440mm sheets

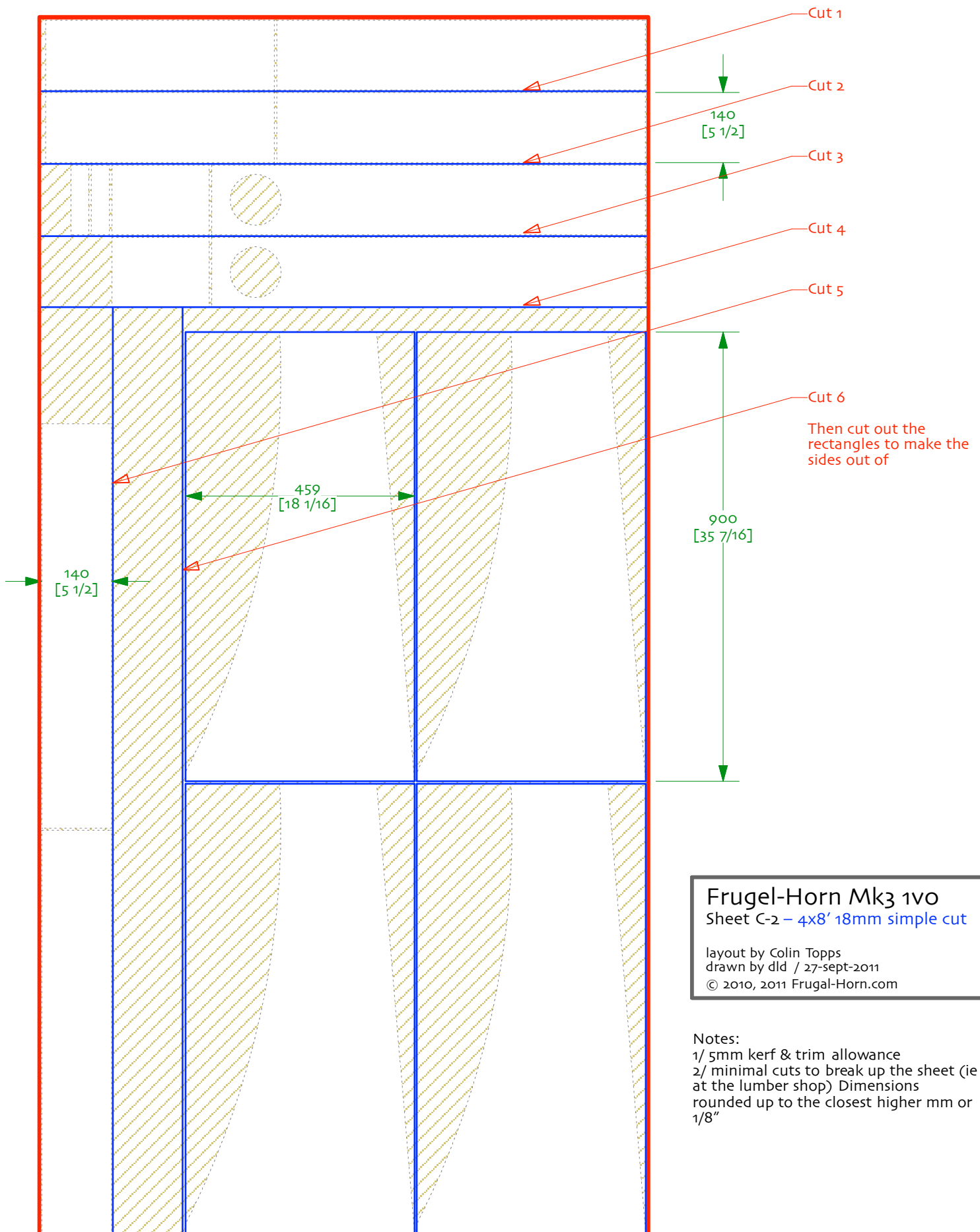

Frugel-Horn Mk3 1v0
 Sheet C-2 – 4x8' 18mm simple cut

layout by Colin Topps
 drawn by dld / 27-sept-2011
 © 2010, 2011 Frugal-Horn.com

Notes:
 1/ 5mm kerf & trim allowance
 2/ minimal cuts to break up the sheet (ie at the lumber shop) Dimensions rounded up to the closest higher mm or 1/8"

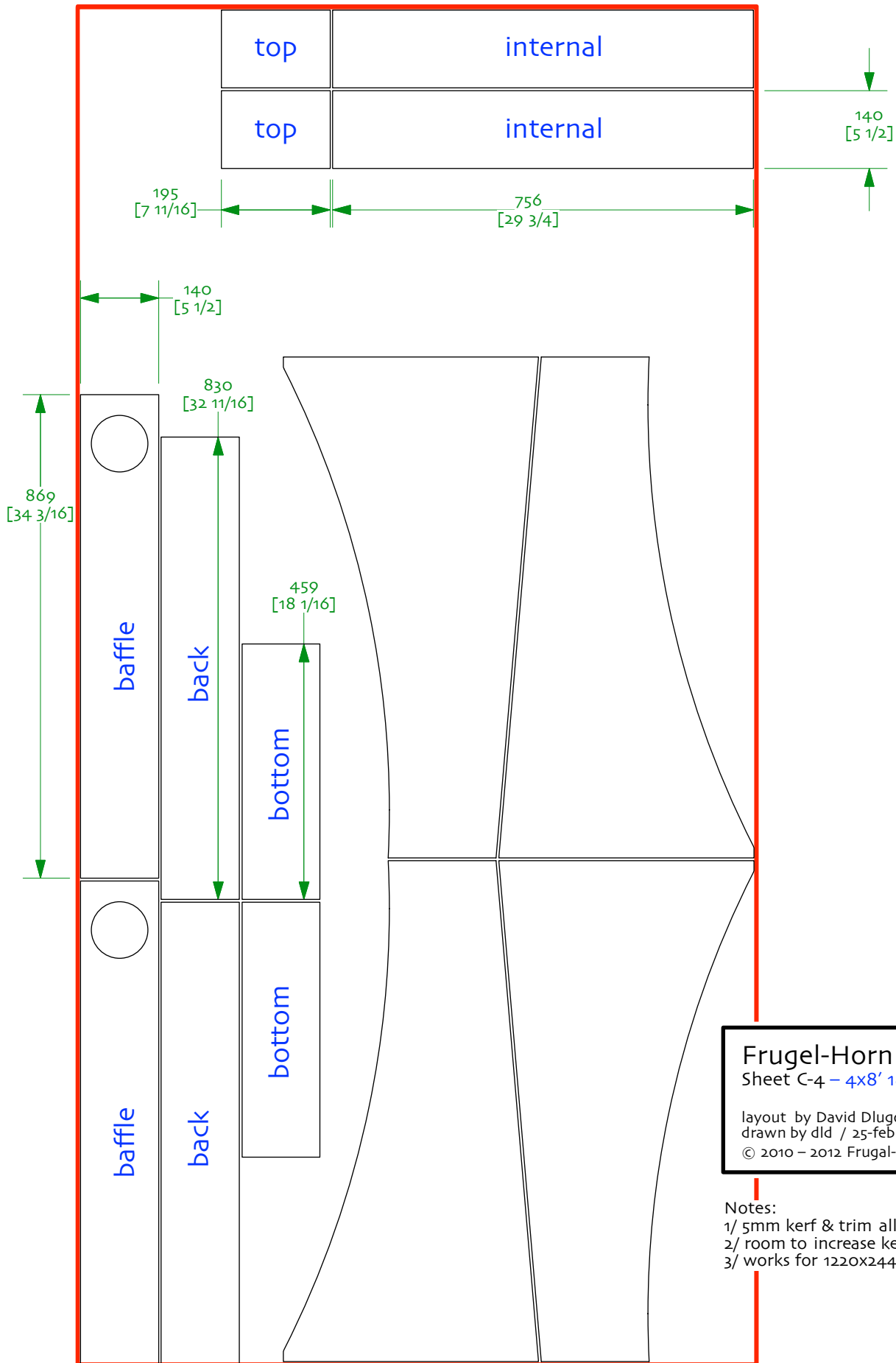

Frugel-Horn Mk3 1v0
 Sheet C-4 – 4x8' 18mm alt cut

layout by David Dlugos
 drawn by dld / 25-february-2012
 © 2010 – 2012 Frugel-Horn.com

- Notes:
- 1/ 5mm kerf & trim allowance
 - 2/ room to increase kerf for CNC
 - 3/ works for 1220x2440mm sheets

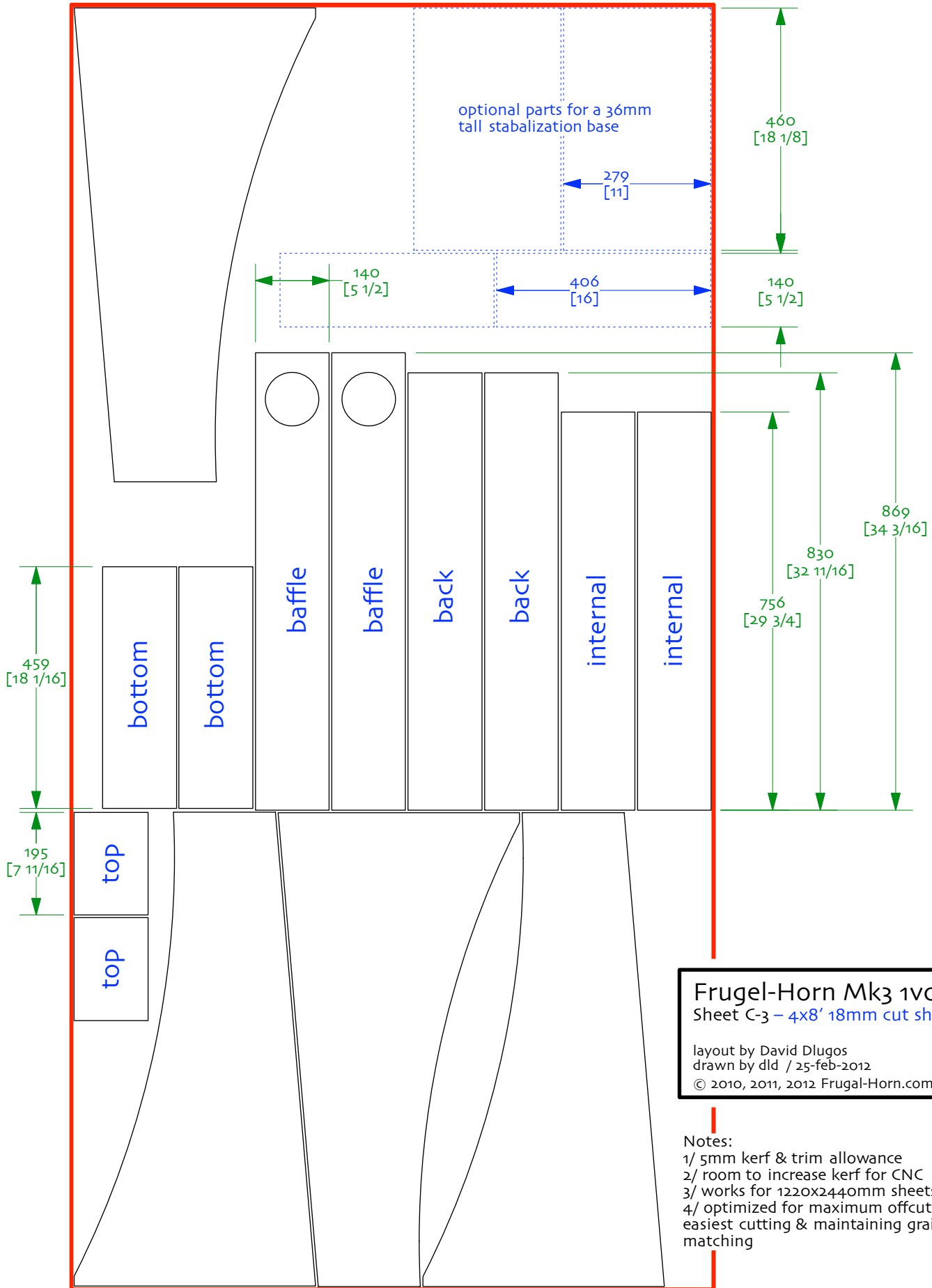

Frugal-Horn Mk3 1v0
 Sheet C-3 – 4x8' 18mm cut sheet

layout by David Dlugos
 drawn by dld / 25-feb-2012
 © 2010, 2011, 2012 Frugal-Horn.com

Notes:
 1/ 5mm kerf & trim allowance
 2/ room to increase kerf for CNC
 3/ works for 1220x2440mm sheets
 4/ optimized for maximum offcut not
 easiest cutting & maintaining grain
 matching