

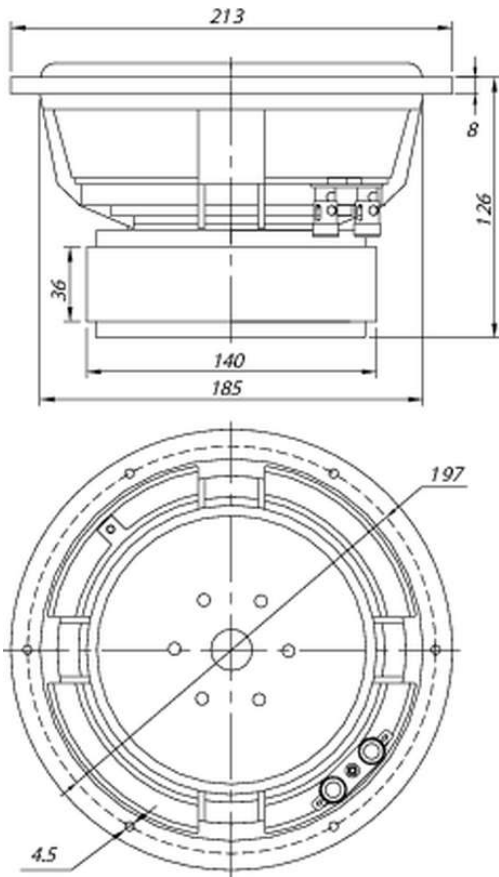

# RSS210HO-4 8" Reference HO Subwoofer 4 Ohm

RSS210HO-4



## PARAMETERS

Impedance	4 ohms
Re	3.6 ohms
Le	0.99 mH @ 1 kHz
Fs	29.6 Hz
Qms	3.33
Qes	0.46
Qts	0.40
Mms	99.3g
Cms	0.29 mm/N
Sd	213.8 cm <sup>2</sup>
Vd	235.2 cm <sup>3</sup>
BL	12 Tm
Vas	18.7 liters
Xmax	11 mm
VC Diameter	50.1 mm
SPL	85.7 dB @ 2.83V/1m
RMS Power Handling	300 watts
Usable Frequency Range (Hz)	30 - 1,500 Hz

## IMPEDANCE/PHASE

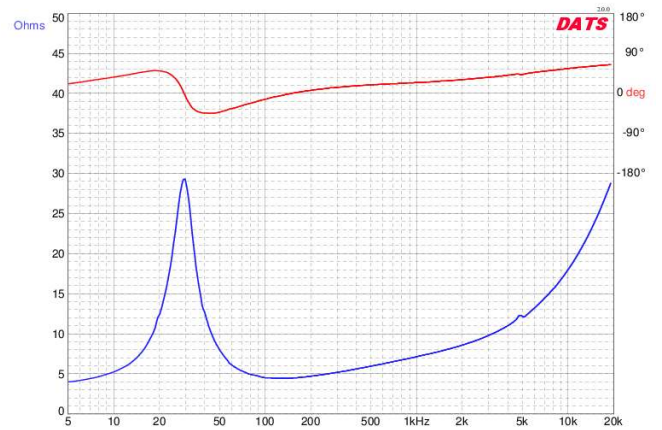

## FEATURES

- Extensively vented motor eliminates compression and allows quiet excursion
- Extra-thick black anodized aluminum cone for maximum rigidity
- Triple shorting ring motor for ultra-low distortion
- 4-layer coil for high power handling
- Optimized parameters for small enclosures

## FREQUENCY RESPONSE

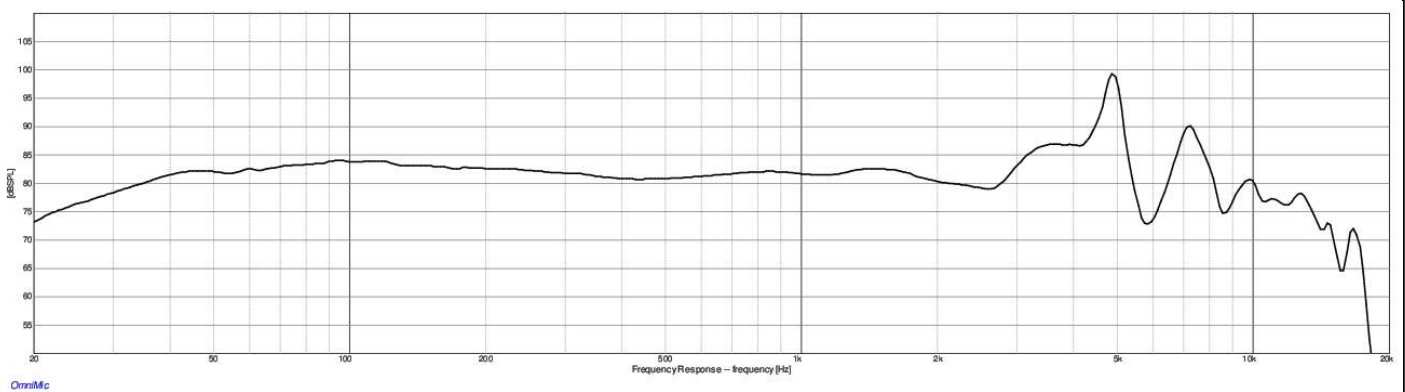

Note: 1/24<sup>th</sup> octave smoothing - nearfield response included in graph below 450 Hz.

Black = 0°