

Classic 1" Tweeter



Type Number: D2905/970000

Features:

The Classic line consists of all the highly regarded transducers that have been appraised and loved by so many customers over the years. The goal has been to assemble all the diamonds, developed over the years, speakers that fully live up to the heritage of the brand.

Driver Highlights: 1" soft dome, SD-2 motor, low compression design, non resonant chamber



Specs:

Electrical Data

Nominal impedance	Zn 6 ohm	
Minimum impedance	Zmin -- ohm	
Maximum impedance	Zo -- ohm	
DC resistance	Re 4.7 ohm	
Voice coil inductance	Le 0.01	mH

T-S Parameters

Resonance Frequency	fs 500	Hz
Mechanical Q factor	Qms --	
Electrical Q factor	Qes --	
Total Q factor	Qts --	
Force factor	Bl 3.5 Tm	
Mechanical resistance	Rms -- Kg/s	
Moving mass	Mms 0.45 g	
Suspension compliance	Cms -- mm/N	
Effective cone diameter	D -- cm	
Effective piston area	Sd 8.5 cm	²
Equivalent volume	Vas -- ltrs	
Sensitivity (2.83V/1m)	89.5	dB

Power handling

100h RMS noise test (IEC)	225 W
Long-term Max Power (IEC 18.3)	-- W
Short Term Max power (IEC 18.2)	-- W

Voice Coil and Magnet Parameters

Voice coil diameter	28 mm
Voice coil height	-- mm
Voice coil layers	--
Height of the gap	-- mm
Linear excursion +/-	0.4 mm
Max mech. excursion +/-	1.5 mm
Flux density of gap	-- mWb
Total useful flux	-- mWb
Diameter of magnet	-- mm
Height of magnet	-- mm
Weight of magnet	-- Kg

Notes:
IEC specs refer to IEC 60268-5 third edition.
All ScanSpeak products are RoHS compliant.

Frequency: D2905/970000

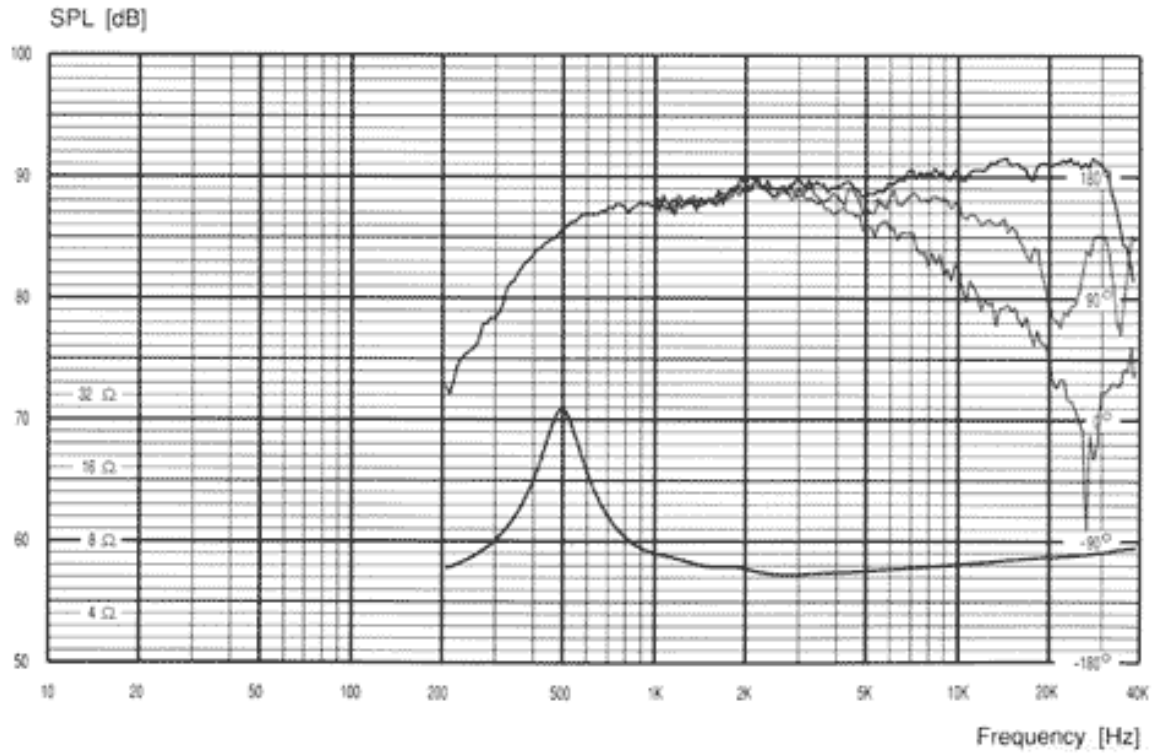

Mechanical Dimensions: D2905/970000

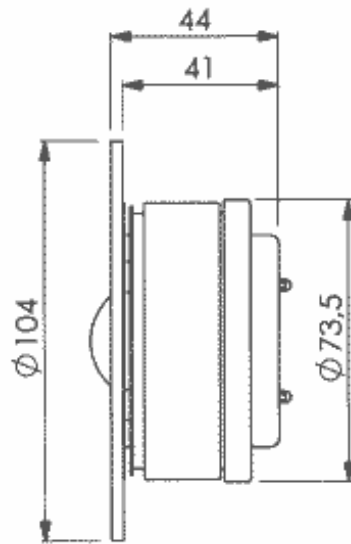
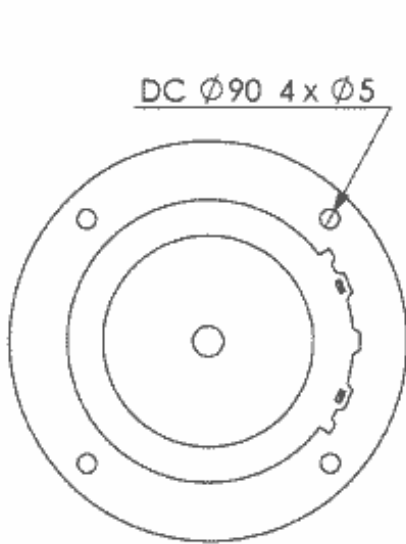

Drawing Dimensions

- Outside Diameter
- Flange Thickness
- Magnet Diameter
- Cutout Diameter
- Interior Depth
- Hole Diameter
- Screw Circle Diameter